

# NUMERACY

## CALCULATOR ALLOWED

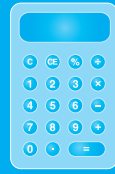

YEAR

9

2011



### SESSION 1

0:40

Time available for students to  
complete test: 40 minutes

Use 2B or HB  
pencil **only**



**Do not write on this page.**

## YEAR 9 NUMERACY (CALCULATOR ALLOWED)

### PRACTICE QUESTIONS

P1

50, 100, 150, 200, 250, ?

Shade one bubble.

Which number comes next in this sequence?

251

260

300

350

P2

Dave had \$5.75.

He spent \$1 and then spent 75 cents.

How much money does he have left?

\$

Write your answer in the box.

P3

268 cents equals

dollars and  cents.

Write your answers in the boxes.



1

Some shapes are shown on this netball court.

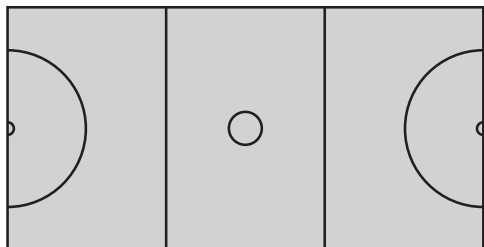

Shade one bubble.



Which shape is **not** shown?

semicircle

circle

square

rectangle

2

The picture shows a set of lights. Two of the lights are off.

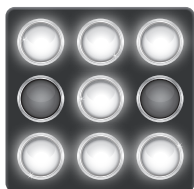

What fraction of the set of lights is off?

$\frac{1}{2}$

$\frac{1}{7}$

$\frac{2}{7}$

$\frac{2}{9}$

3

What number makes this number sentence correct?

$$1.6 \times \boxed{?} = 4.48$$

2.8

2.88

6.08

7.168

4

Only one of these shapes has two acute angles and two obtuse angles.

Which shape is it?

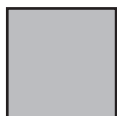









5

These pictures show the dials for four fuel tanks.  
Which dial shows that the tank is about 75% full?

Shade one bubble.

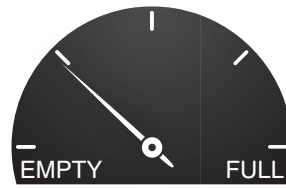
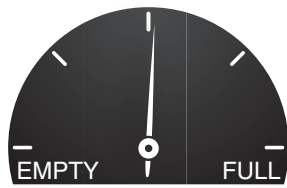
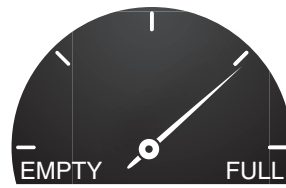
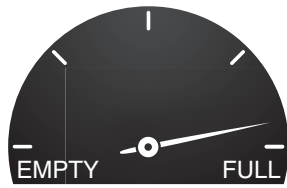

6

Jane cut this shape out of card.

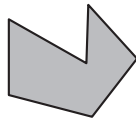

She flipped the shape over.

Which of these could the shape look like after Jane flipped it over?

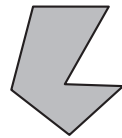
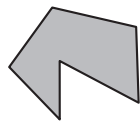
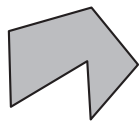

7

For any prism the surface area ( $S$ ) is calculated by multiplying the perimeter of its base ( $p$ ) by its height ( $h$ ) and adding twice the area of the base ( $A$ ).

Which one of these formulas could be used for this calculation?

- $S = 2phA$
- $S = ph + A$
- $S = ph + 2A$
- $S = 2ph + 2A$

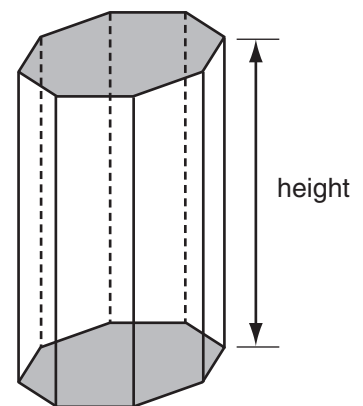



8

When Eli moved to Australia, the population was 22 112 277 people.

Shade one bubble.



How many people is that to the nearest million?

- 20 000 000
- 22 000 000
- 22 100 000
- 22 110 000

9

Jim builds 4 garden beds arranged in an L-shape.

Jim and his garden beds are shown on the plan below.

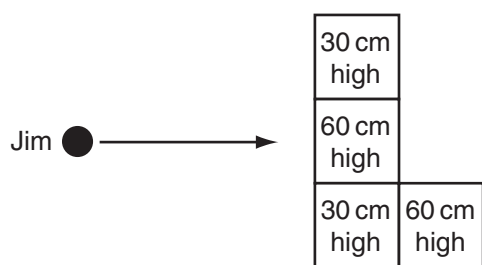

Which view of the beds would Jim see?



10

Miriam owns a restaurant.

She sets up rows of tables and chairs as shown.

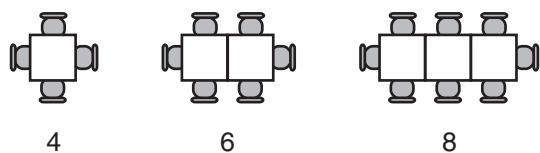

Which of these rules can be used to work out how many chairs will be needed on any row of tables?

- $\text{number of tables} \times 4$
- $\text{number of tables} \div 2 - 2$
- $\text{number of tables} \times 2 + 2$
- $\text{number of tables} \times 2 - 2$



11

Two bricks can be placed together face-to-face to form three different rectangular prisms. Two of them are shown here.

Shade one bubble.

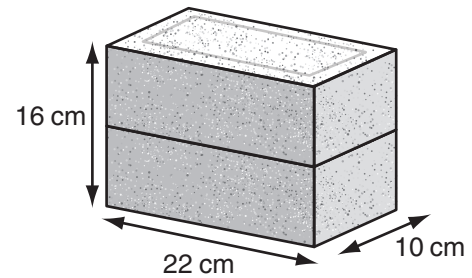
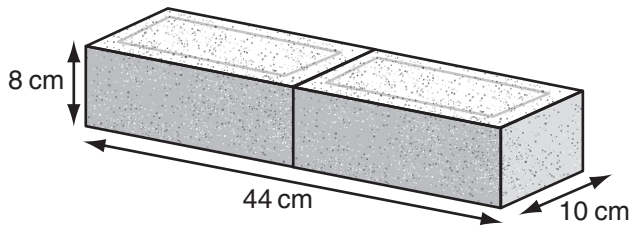

What would be the measurements of the third prism?

- 11 cm by 16 cm by 10 cm
- 22 cm by 20 cm by 8 cm
- 32 cm by 22 cm by 10 cm
- 44 cm by 16 cm by 5 cm

12

Peter wants to paint his bedroom walls.

What information will best help him decide how much paint to buy?

- volume of room
- capacity of room
- perimeter of all walls
- area of all walls

13

The length of Robin's soccer field is 125 m. Robin is making a scale model of the field using a ratio of 1 : 500.

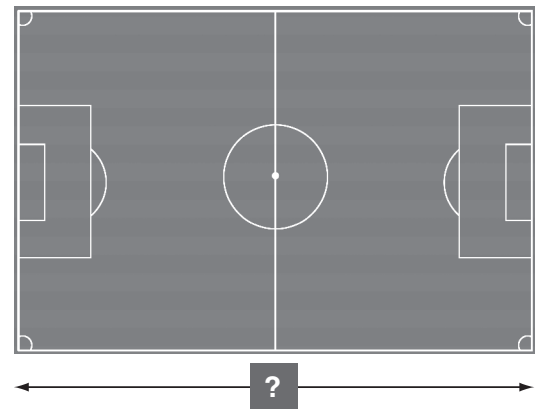

How long should Robin make the model soccer field?

- 4 cm
- 25 cm
- 40 cm
- 250 cm

# YEAR 9 NUMERACY (CALCULATOR ALLOWED)



14

The value of  $y$  is given by the rule  $y = 4 - x^2$ .

What is the value of  $y$  when  $x = 1.5$ ?

- 1                       1.75                       2.5                       6.25

Shade one bubble.



15

Internet use in Australia				
Year	2003	2004	2005	2006
Number of people (millions)	12.21	13.27	13.60	14.28

Between 2003 and 2006, internet use in Australia increased by about

- 0.5 million people.  
 1 million people.  
 2 million people.  
 2.5 million people.

16

Dustin collects football cards.

He sells some of his cards. The prices are listed here.

\$3, \$5, \$5, \$8, \$8, \$10, \$10, \$10, \$40

What is their mean (average) price?

- \$8                       \$9                       \$10                       \$11

17

This label was on the side of a bottle of juice.

	Per bottle	Per 100 mL
Energy	648 kJ	182 kJ

What was the size of the bottle of juice to the nearest mL?

- 1179 mL                       830 mL                       466 mL                       356 mL



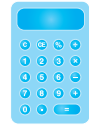

18

When this kettle is full of water it has a mass of 2900 grams.

Write your answer in the box.



When the kettle is half full of water it has a mass of 2050 grams.

What is the mass of the kettle when it is empty?

grams

19

This picture shows a position used in the sport of fencing.

Shade one bubble.

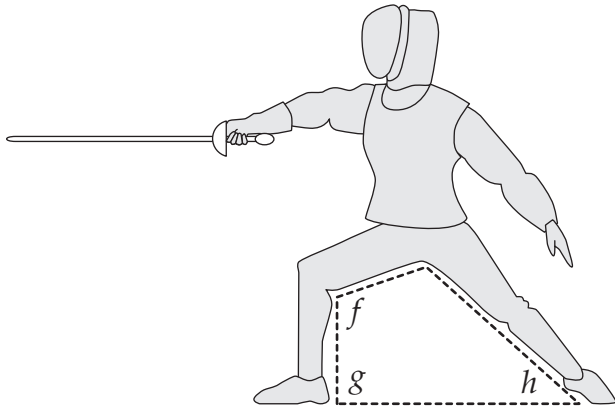

Which list shows the three angles  $f, g, h$  in **increasing** order of size?

- $h, g, f$      
   $h, f, g$      
   $g, f, h$      
   $f, g, h$

20

A bag contains 50 coloured marbles.

This table shows how many marbles of each colour are in the bag.

<b>Colour</b>	red	yellow	orange	green	blue
<b>Number</b>	10	5	20	5	10

One marble is picked at random from the bag.

What is the probability of the marble being red **or** yellow?

- 0.1     
  0.15     
  0.2     
  0.3



21

Which of these percentages is closest in value to  $\frac{7}{9}$ ?

Shade one bubble.

76%

77%

78%

79%

22

The table shows the charges for hiring this boat.

$h$ (number of hours hired)	1	2	3	4	5
$c$ (charge \$)	25	45	65	85	105



Which rule shows the relationship between  $c$  and  $h$ ?

$c = 20 + 5h$

$c = 5 + 20h$

$c = 25 + 20h$

$c = 20 + 25h$

23

A factory makes metal boxes. The base and sides of the boxes are rectangular. The height of each box is 0.8 metres.

Which box has a volume of 0.16 cubic metres?

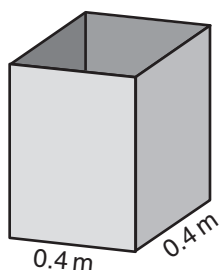

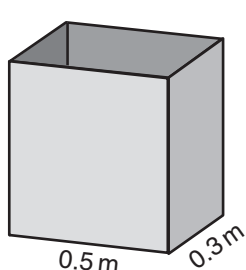

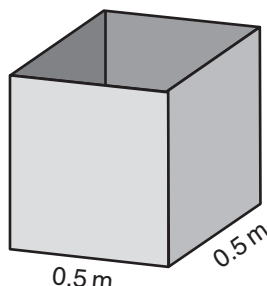

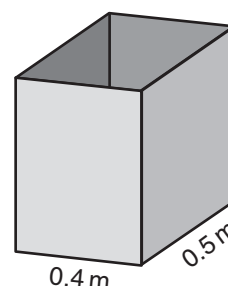



24

Tam cuts letters from squares of metal.

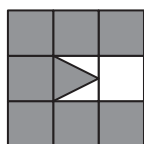
Which of these letters uses exactly  $\frac{5}{6}$  of the metal square?

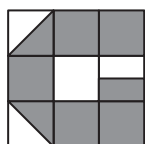

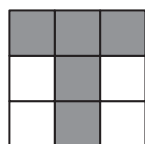



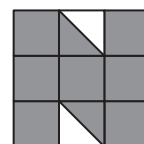

# YEAR 9 NUMERACY (CALCULATOR ALLOWED)



25

A horse trots in a circle at the end of a 4 metre rope.

Shade one bubble.

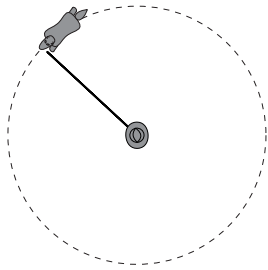

About how far has the horse trotted after completing 10 circles?

25 metres

50 metres

125 metres

250 metres

26

A shop sells these four perfumes.



**Argent**  
90 mL for \$99



**Bucci**  
150 mL for \$160



**Cutie**  
30 mL for \$30



**Davois**  
50 mL for \$45

Which perfume has the **highest** price per mL?

Argent

Bucci

Cutie

Davois

27

Kyle draws a quadrilateral with a perimeter of 30 centimetres.

What is the maximum possible area of Kyle's shape?

Write your answer in the box.

square centimetres

28

The table shows the height of a burning candle at different times.

<b>Time (minutes)</b>	0	5	10	15	20	25	30
<b>Height (cm)</b>	15	14.25	13.5	12.75	12	11.25	10.5

The candle burns until its height is 3 cm.

How many minutes does it take the candle to burn to a height of 3 cm?

minutes

# YEAR 9 NUMERACY (CALCULATOR ALLOWED)



29

Amanda sells T-shirts at a market for \$15 each.  
Her costs are \$6 per T-shirt and \$540 per month rent.

Write your answer in the box.

How many T-shirts must Amanda sell per month to equal her monthly costs?

30

A builder needs 6.5 cubic metres of concrete for a job.  
This table shows the mixture for the concrete.

cement	sand	small stones	water
2 parts	4 parts	6 parts	1 part

How many cubic metres of sand does the builder need?

 cubic metres

31

A rectangular sheet of paper had a width of 841 millimetres.  
Its area was 1 square metre.

What was its length to the nearest millimetre?

 millimetres

32

In this drawing,  $ACD$  is an isosceles triangle and  $BC = DE$ .

Write your answers in the boxes.

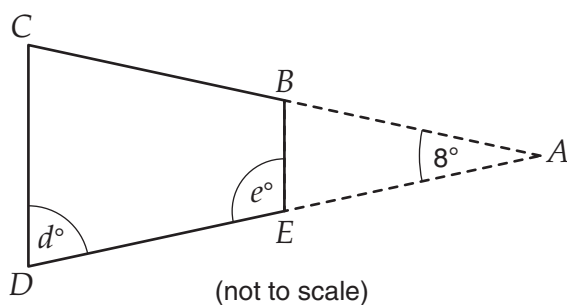

What are the sizes of the two marked angles,  $d$  and  $e$ ?

$d =$    $^{\circ}$        $e =$    $^{\circ}$

**STOP – END OF TEST**

**YEAR 9 NUMERACY (CALCULATOR ALLOWED)**



**Do not turn this page.**

NATIONAL ASSESSMENT PROGRAM  
LITERACY AND NUMERACY

# NUMERACY NON-CALCULATOR



YEAR

9

2011

SESSION 2

0:40

Time available for students to  
complete test: 40 minutes

Use 2B or HB  
pencil **only**



# YEAR 9 NUMERACY (NON-CALCULATOR)



1

Lucy walked along the path from the ranger's hut to the lookout.

Shade one bubble.

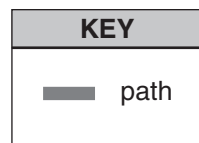
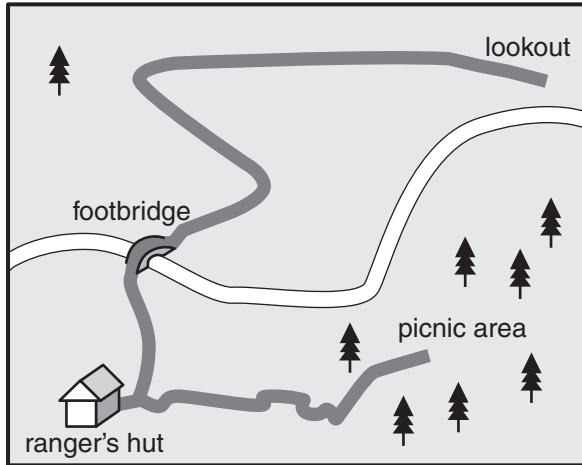

Which set of directions best describes her path to the lookout?

- north, north-east, north-west then west
- north, north-west, north-east then west
- north, north-east, north-west then east
- north, north-west, north-east then east

2

Which of these shows the **smallest** change in temperature?

- from  $-10^{\circ}\text{C}$  to  $-5^{\circ}\text{C}$
- from  $-4^{\circ}\text{C}$  to  $0^{\circ}\text{C}$
- from  $-3^{\circ}\text{C}$  to  $3^{\circ}\text{C}$
- from  $4^{\circ}\text{C}$  to  $6^{\circ}\text{C}$

3

Ruth made this model using 8 foam balls for the vertices and 12 sticks for the edges.

How many foam balls and sticks would Ruth need to make a **square-based pyramid**?

- 5 foam balls and 8 sticks
- 5 foam balls and 6 sticks
- 4 foam balls and 6 sticks
- 6 foam balls and 9 sticks

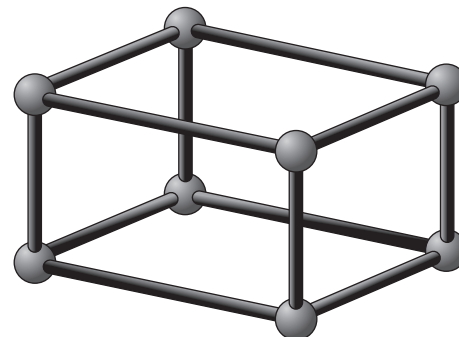

# YEAR 9 NUMERACY (NON-CALCULATOR)



4

The table shows the times of 3 of the first 4 swimmers in a race.

Shade one bubble.

1st place	25.38 seconds
2nd place	25.83 seconds
3rd place	?
4th place	26.29 seconds

The time of the swimmer in 3rd place could be

- 25.78 seconds.
- 25.91 seconds.
- 26.31 seconds.
- 26.92 seconds.

5

Tim had \$32 to spend while on holiday.  
He spent exactly the same amount each day.  
At the end of the holiday he had no money left.

Which of these could be the amount he spent each day?

- |                       |                       |                       |                       |
|-----------------------|-----------------------|-----------------------|-----------------------|
| \$6                   | \$5                   | \$4                   | \$3                   |
| <input type="radio"/> | <input type="radio"/> | <input type="radio"/> | <input type="radio"/> |

6

This drawing shows a flat sheet of cardboard that can be folded to make a box.  
The box has a picture of an apple on one side only, as shown.

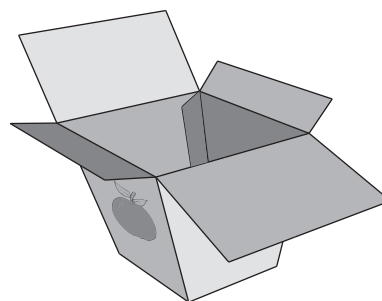
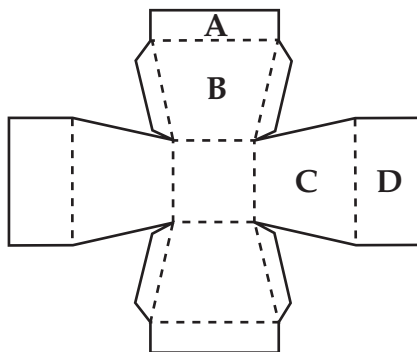

Which part of the flat sheet could have the picture on it?

- |                       |                       |                       |                       |
|-----------------------|-----------------------|-----------------------|-----------------------|
| Part A                | Part B                | Part C                | Part D                |
| <input type="radio"/> | <input type="radio"/> | <input type="radio"/> | <input type="radio"/> |



# YEAR 9 NUMERACY (NON-CALCULATOR)



7

When it is 11 am in Perth, it is 3 pm in Auckland on the same day.  
At 9 pm in Perth, Sophie phoned a friend in Auckland.

Shade one bubble.



What was the time in Auckland when Sophie phoned?

1 am

5 am

1 pm

5 pm

8

Jack drew this graph to show how attendance at concerts is related to ticket price.

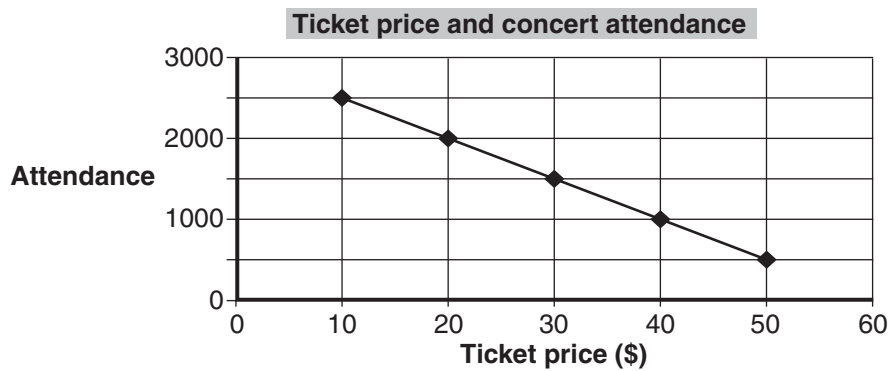

Which statement best describes the graph?

- As the ticket price goes up, attendance goes down.
- As the ticket price goes up, attendance goes up.
- As the ticket price goes down, attendance goes down.
- As the ticket price goes down, attendance stays the same.

9

This table is a training schedule for a walking group.

Week number	Week 1	Week 2	Week 3	Week 4
Daily distance	5 km	6 km	8 km	?

The daily distance increases from week to week. It follows the rule:

Double the previous week's daily distance and subtract 4 km.

What is the daily distance for Week 4?

9 km

10 km

12 km

20 km

# YEAR 9 NUMERACY (NON-CALCULATOR)



10

Bruce is cooking dinner.  
The table shows the cooking times for his dinner.

Shade one bubble.

	Cooking time
Chicken	1 hour 40 minutes
Potatoes	20 minutes
Peas	10 minutes

Bruce starts cooking the chicken at 5:10 pm.  
He wants everything to finish cooking at the same time.

At what time should Bruce start cooking the peas?

- 6:20 pm      6:30 pm      6:40 pm      6:50 pm
- 

11

The top view and front view of a building are shown.

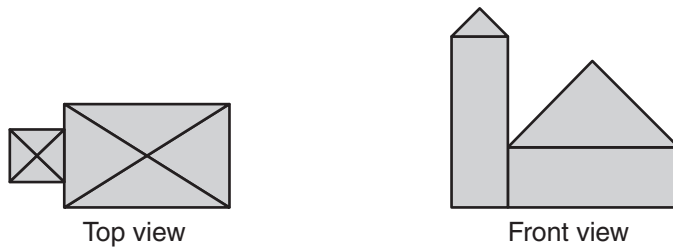

Which could be the side view of this building?

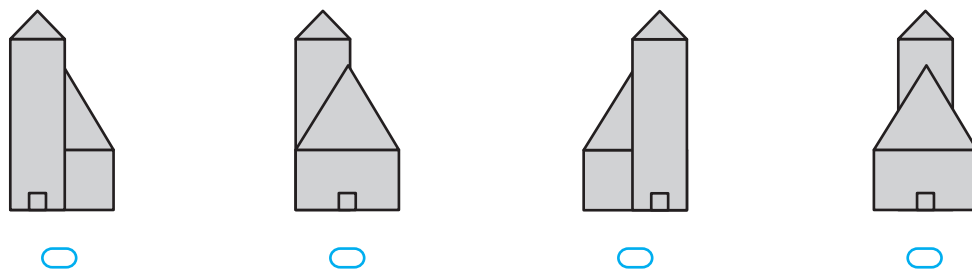

# YEAR 9 NUMERACY (NON-CALCULATOR)



12

Which position is closest to  $\frac{2}{3}$  on this number line?

Shade one bubble.

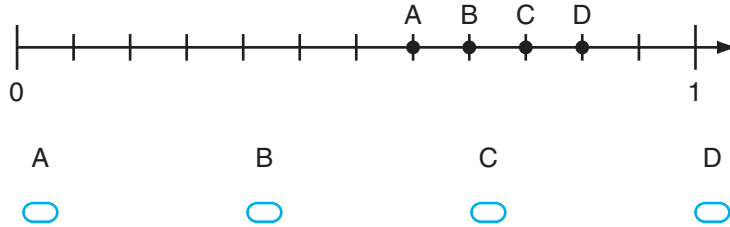

13

This diagram shows a rectangular school yard. The shaded area is the playground. The lunch area is a square of side length 8 m.

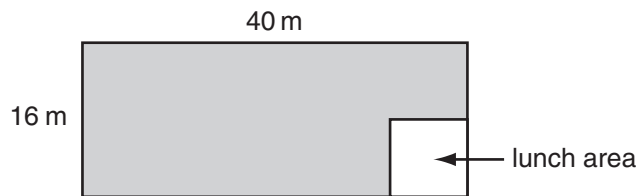

Which of these expressions gives the area of the playground?

$(40 \times 16) - (8 \times 8)$



$(32 \times 8) + (8 \times 8)$



$(40 + 16) - (8 + 8)$



$(40 \times 16) + (8 \times 8)$



14

A section of an 8-strand wire fence is shown. The fence has 3 barbed wire strands and 5 plain wire strands.

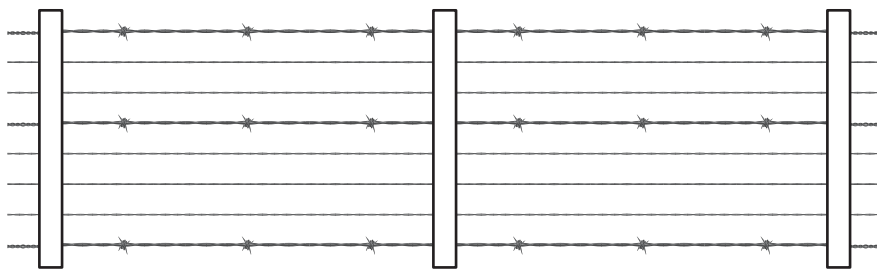

Barbed wire costs  $\$b$  per metre. Plain wire costs  $\$p$  per metre.

Which of these expressions gives the total cost of the wire needed for a fence of length  $L$  metres?

$8bpL$



$15bpL$



$8(b + p)L$



$(3b + 5p)L$



## YEAR 9 NUMERACY (NON-CALCULATOR)



15

This regular hexagon has been made by putting together 3 identical smaller shapes.

Shade one bubble.

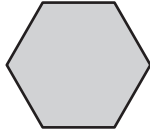

Which of these could be that smaller shape?



16

Jane buys a 1.25 L bottle of drink and a 375 mL can of drink.

How much drink does she buy?

376.25 mL



500 mL



1.525 L



1.625 L



17

Sally has seen four movies.

The ticket prices were \$13, \$8, \$10 and \$10.

The next movie she plans to see is in 3D and the ticket price is \$34.

Which of these will **not** change after Sally sees the next movie?

- the median of her ticket prices
- the mean of her ticket prices
- the range of her ticket prices
- the total cost of her tickets

18

Jade buys a 500 gram bag of beads at a market.

Each bead has a mass of 0.48 grams.

Which of these is the best estimate for the number of beads in the 500 gram bag?

100



250



1000



2500





# YEAR 9 NUMERACY (NON-CALCULATOR)



19

Elli was playing a video game.  
In the game she had to collect objects that are worth points.  
The pictures show how many points she scored in three games.

Write your answer  
in the box.

Game 1	Game 2	Game 3
		
170 points	150 points	120 points

In Game 4 she collected these three objects: 

How many points did she score in Game 4?

20

Nadia went on a bus trip in Queensland.  
Her bus left at 8:45 am. It arrived at 2:35 pm on the same day.

Shade one  
bubble.

How long did Nadia's bus trip take?

- 5 hours 50 minutes
- 6 hours 10 minutes
- 6 hours 50 minutes
- 7 hours 50 minutes

21

80 students were asked if they had an MP3 player, a DVD player or both.

	MP3 player	No MP3 player
DVD player	36	12
No DVD player	6	26

How many students had a DVD player?

- 12     
  36     
  42     
  48

## YEAR 9 NUMERACY (NON-CALCULATOR)



22

Which one of the following triangles is **impossible** to draw?

Shade one bubble.

- an isosceles triangle with one right angle
- an equilateral triangle with one right angle
- a scalene triangle with one obtuse angle
- an isosceles triangle with three acute angles

23

Sam buys 16 tickets to a concert.

The tickets cost \$27 each.

Which of these could Sam use to calculate the total cost?

- $(27 \times 10) + 6$
- $(27 \times 10) \times 6$
- $(20 \times 10) + (7 \times 6)$
- $(27 \times 10) + (27 \times 6)$

24

In a class there are 24 students.

The ratio of students born in Australia to those born overseas is 5:3.

How many students in the class were born overseas?

- |                       |                       |                       |                       |
|-----------------------|-----------------------|-----------------------|-----------------------|
| 3                     | 6                     | 8                     | 9                     |
| <input type="radio"/> | <input type="radio"/> | <input type="radio"/> | <input type="radio"/> |

25

A number of students were asked this question:

“How many cousins do you have?”

Write your answer in the box.

The lowest answer given was 6.

The highest answer given was 20.

The total of all the answers given was 50.

What is the **smallest** number of students who could have been asked?

students

# YEAR 9 NUMERACY (NON-CALCULATOR)



26

In February 2010, the population of the world was approximately 6 800 000 000 people.

Shade one bubble.

Another way of writing this number is

$6.8 \times 10^8$

$6.8 \times 10^9$

$68 \times 10^9$

$68 \times 10^{10}$



27

Three friends were making cupcakes for a party.  
 Josh made 10 more cakes than Alice.  
 Alice made 8 more cakes than Tom.  
 In total they made 62 cakes.

Write your answer in the box.

How many cakes did **Tom** make?

28

The diagram shows some measurements of a courtyard.

What is the area of the courtyard in square metres?

square metres

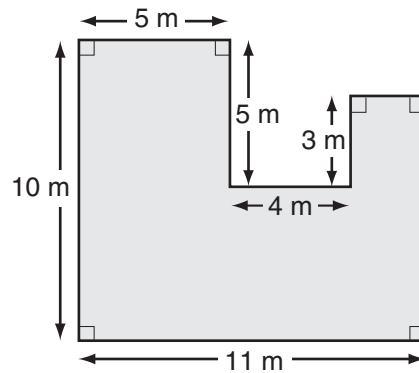

29

This design is drawn inside a regular hexagon.

What is the size of the angle marked  $a$ ?

degrees

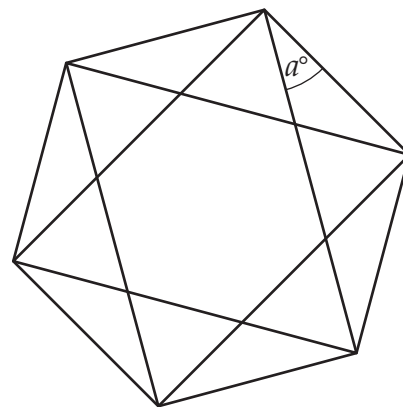

## YEAR 9 NUMERACY (NON-CALCULATOR)



30

When 1 mm of rain falls on 1 m<sup>2</sup> of the surface of a pond, 1 litre of water is collected.

Write your answer in the box.



What surface area of the pond is needed to collect 10 000 litres from a rainfall of 20 mm?

m<sup>2</sup>

31

A jockey rode a horse for 1200 metres. The time for each 400 metres is shown in the table.

Distance	Time
First 400 metres	29 seconds
Next 400 metres	27 seconds
Last 400 metres	24 seconds

What was the average speed for the 1200 metre ride, in metres per second?

metres per second

32

Ben put six rectangular sheets of paper on top of each other to make this spiral design.

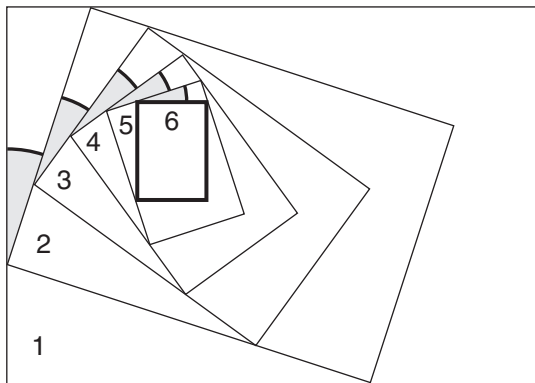

All of the shaded angles are equal. Sheet 6 is at right angles to sheet 1.

What is the size of a shaded angle?  degrees

**STOP – END OF TEST**